

鎢鋼 4刃球形立銑刀

TUNGSTEN CARBIDE 4-FLUTE BALL END MILL

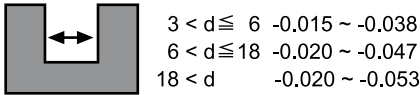

- 超細微粒碳化鎢材質
- Micro-Grain Tungsten Carbide

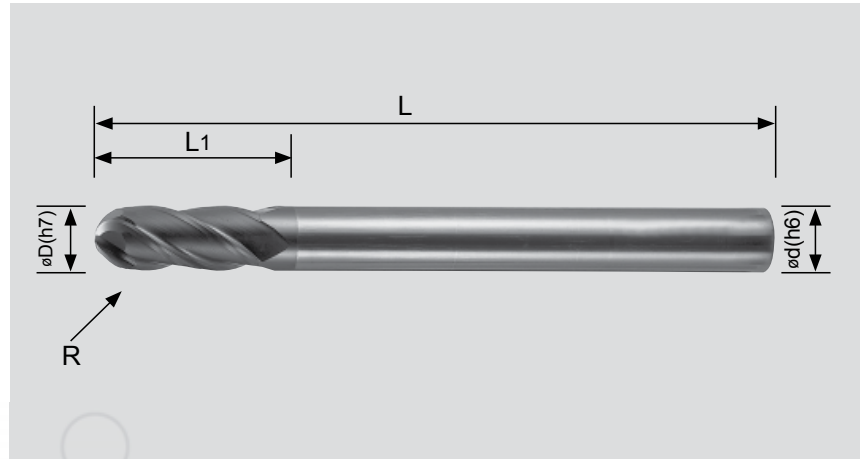

適合材質：

碳素鋼、模具鋼、合金鋼、工具鋼、
鑄鐵、不鏽鋼、
熱處理鋼、焊補鋼料。

Applicable material:

Carbon steel, mold steel, tool steel,
alloy steel, cast iron, stainless steel,
heat-treated steel, welded steel.

單位: Unit : mm

型號 EDP NO.	刃徑 D Flute Dia.	R徑 Radius	刃長 L1 Length of Cut	全長 L Overall Length	柄徑 d Shank Diameter	刃數 Flute Number	AK45	AK925	PK66
4BE-R3.0L50	6.0	R 3.0	12.0	50	6.0	4	●	●	●
4BE-R3.0L75	6.0	R 3.0	12.0	75	6.0	4	●	●	●
4BE-R4.0L60	8.0	R 4.0	16.0	60	8.0	4	●	●	●
4BE-R4.0L100	8.0	R 4.0	16.0	100	8.0	4	●	●	●
4BE-R5.0L75	8.0	R 4.0	20.0	75	8.0	4	●	●	●
4BE-R5.0L100	10.0	R 5.0	20.0	100	10.0	4	●	●	●
4BE-R6.0L75	12.0	R 6.0	20.0	75	12.0	4	●	●	●
4BE-R7.0L100	14.0	R 7.0	24.0	100	14.0	4	●	●	●
4BE-R8.0L100	16.0	R 8.0	24.0	100	16.0	4	●	●	●
4BE-R10.0L150	20.0	R 10.0	30.0	150	20.0	4	●	●	●
4BE-R12.5L150	25.0	R 12.5	35.0	150	25.0	4	●	●	●

註: 有●者表示有庫存

NOTE: ● means items in stock

切削條件表請參考第74頁